



3MXTD

Drive Hydraulic Torque Wrench

Operation & Maintenance Manual



Pingyuan Jingke Hydraulic Co., Ltd.

Catalogue

- I. Acceptance notice (unpacking inspection)
- II. Product description
- III. Warning
- IV. Recommendation table of bolt pre-tightening force
- V. Operation and Use
- VI. MXTD Hydraulic Torque Wrench Pressure-torque Comparison Table
- VII. MXTD exploded diagram and details
- VIII. After-sales Service

Pingyuan Jingke Hydraulic Co., Ltd.

TEL: 0531-82899663

Email: torcstark@gmail.com

Address: Juncang Industrial Park, Pingyuan, Dezhou, China

Operation & Maintenance Manual of Hydraulic Torque Wrench

This operating manual includes operating procedures, warnings and precautions, and troubleshooting of the MXTD series hydraulic torque wrench. Before use, please read this manual carefully, thoroughly understand its content and keep it properly. This manual is only for the end user's reference.

I. Acceptance notice (unpacking inspection)

Check carefully whether there is any damage to the appearance of the product and whether there is any transportation damage. Transportation damage is not covered by the warranty. If it is found to be damaged due to cargo transportation, it should be reported to the freight forwarder in time. The freight forwarder shall pay for all repair and replacement costs caused by transportation damage.

Safety first

Hydraulic torque wrench is a power tool. Read all instructions, warnings and precautions carefully before use, and follow safety measures to avoid personal or equipment damage when operating the equipment! We are not responsible for damage caused by unsafe operation and wrong operation.

II. Product description

The MXTD hydraulic torque wrench is made of aluminum-titanium alloy and ultra-high-strength alloy materials. It is manually controlled and has a double-acting hydraulic design, which can tighten and loosen bolt connections. It is widely used for the dis-assembly of high torque bolts, the torque is accurately adjustable, and the error does not exceed $\pm 3\%$.

MXTD Hydraulic Torque Wrench:

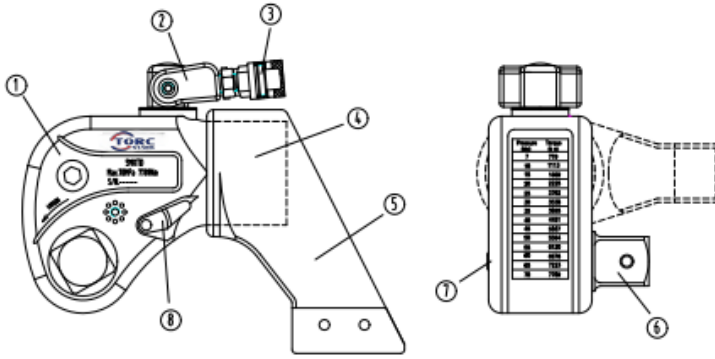

| No. | Items |
|-----|-------------------------------|
| ① | Wrench body |
| ② | 360°x180°rotary joint |
| ③ | Quick connector |
| ④ | 360° fine-tuning reaction arm |
| ⑤ | Reaction arm |
| ⑥ | Square drive shaft |
| ⑦ | Drive shaft locker |
| ⑧ | Quick release trigger |

Figure (1)

3MXTD Technical Parameters:

Dimension

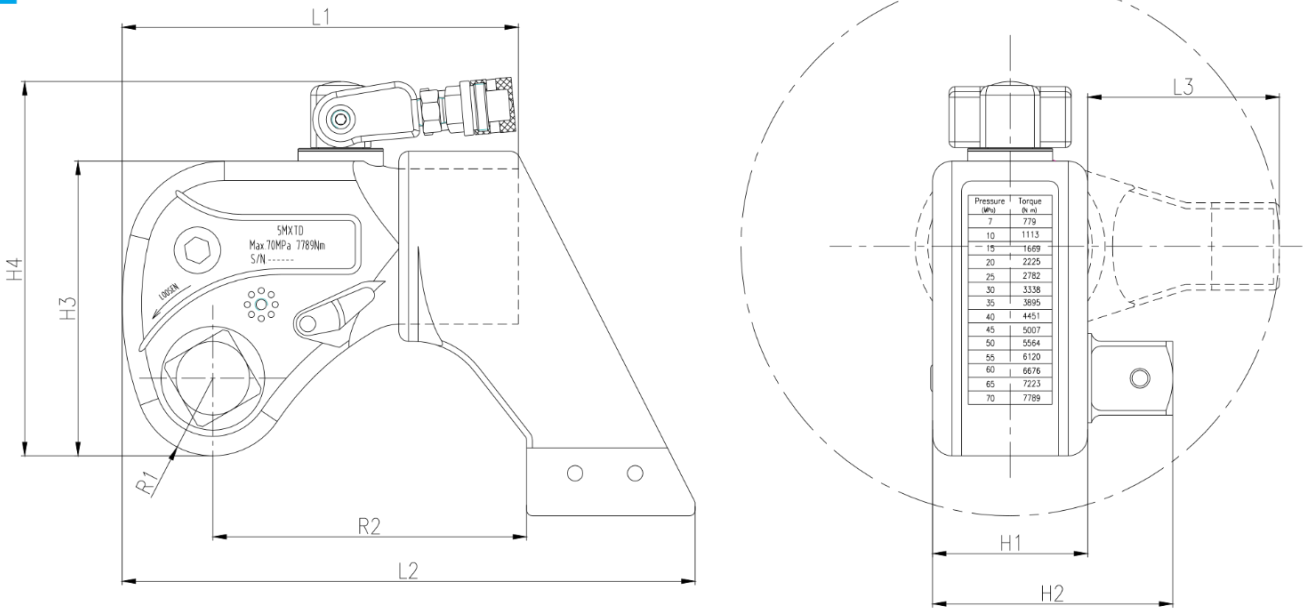

| Model | Torque (Nm) | Weight (kg) | L1 | L2 | L3 | H1 | H2 | H3 | H4 | R1 | R2 | Square drive |
|-------|-------------|-------------|-----|-----|----|----|----|-----|-----|----|-----|--------------|
| 3MXTD | 436-4364 | 4.8kg | 168 | 244 | 79 | 70 | 99 | 125 | 165 | 34 | 132 | 1' |

III. Warning

 Warning: To avoid personal injury and possible equipment damage, ensure that each hydraulic component can withstand a working pressure of 700bar.

 Warning: Do not exceed the rated load of the equipment

Minimize the risk of overloading; use a pressure gauge in the system to display the operating load. The pressure gauge is a window of what happens in the system.

Do not exceed the maximum allowable torque when using a hydraulic wrench.

 Warning: Try to replace worn-out parts with original Jingke parts

 Note: Avoid damage to hydraulic tubing

Avoid serious bending and entanglement of hydraulic tubing during use. The use of bent or wound tubing will produce excessive back pressure. Severe bending and entanglement will damage the inside of the tubing and cause it to be scrapped prematurely.

Do not drop or press heavy objects on the oil pipe. Severe impact can cause damage to the metal wires inside the tubing, and the damaged tubing may rupture when pressurized.

Do not use hydraulic tubing to pull or lift other hydraulic components (such as pumps, hydraulic wrenches, valves, etc.).

 Warning: In order to avoid damage to the equipment and personal injury, do not remove the protective plate on the wrench, do not modify the wrench and accessories, and do not change the safety valve on the rotary joint.

 Note: Incorrect connection will cause malfunction and danger. Keep the quick connector clean before connecting, and screw on the dust cap after use

 Note: Do not use worn-out sockets and plugs. Do not use metric sockets to twist inch nuts and bolts, and vice versa.

 Warning: Use Jingke original high-performance sockets.

 Warning: Fasten the drive head of the socket with a pin to prevent the socket from falling off.

IV. Recommendation table of bolt pre-tightening force

| Strength grade | | 4.8 | | 6.8 | | 8.8 | | 10.9 | | 12.9 | |
|---------------------------|-------------------|--------------------------|-------|--------------------------------|-------|-------------------------------|-------|--|--------|--|--------|
| Minimum breaking strength | | 400MPa | | 600MPa | | 800MPa | | 1000MPa | | 1200MPa | |
| Material | | General structural steel | | Steel for mechanical structure | | Chrome Molybdenum Alloy Steel | | Nickel-chromium-molybdenum alloy steel | | Nickel-chromium-molybdenum alloy steel | |
| Bolt | Nut opposite side | Torque value | | Torque value | | Torque value | | Torque value | | Torque value | |
| M | S | KGM | NM | KGM | NM | KGM | NM | KGM | NM | KGM | NM |
| 16 | 24 | 9 | 87 | 13 | 131 | 18 | 174 | 25 | 245 | 30 | 294 |
| 18 | 27 | 13 | 128 | 20 | 192 | 26 | 256 | 37 | 360 | 44 | 432 |
| 20 | 30 | 17 | 170 | 26 | 256 | 35 | 341 | 49 | 479 | 59 | 575 |
| 22 | 34 | 24 | 232 | 36 | 348 | 47 | 465 | 69 | 653 | 80 | 784 |
| 24 | 36 | 30 | 294 | 45 | 442 | 60 | 589 | 84 | 828 | 101 | 994 |
| 27 | 41 | 44 | 432 | 66 | 647 | 88 | 863 | 124 | 1214 | 149 | 1457 |
| 30 | 46 | 60 | 585 | 89 | 877 | 119 | 1171 | 168 | 1646 | 201 | 1975 |
| 33 | 50 | 81 | 796 | 122 | 1195 | 162 | 1593 | 228 | 2240 | 274 | 2688 |
| 36 | 55 | 104 | 1023 | 157 | 1535 | 209 | 2046 | 294 | 2878 | 352 | 3453 |
| 39 | 60 | 135 | 1324 | 203 | 1986 | 270 | 2649 | 380 | 3725 | 456 | 4469 |
| 42 | 65 | 167 | 1638 | 251 | 2457 | 334 | 3277 | 470 | 4608 | 564 | 5529 |
| 45 | 70 | 209 | 2045 | 313 | 3068 | 417 | 4090 | 587 | 5752 | 704 | 6903 |
| 48 | 75 | 251 | 2461 | 376 | 3691 | 502 | 4921 | 706 | 6921 | 847 | 8305 |
| 52 | 80 | 325 | 3181 | 487 | 4771 | 649 | 6362 | 913 | 8946 | 1095 | 10736 |
| 56 | 85 | 404 | 3956 | 605 | 5934 | 807 | 7912 | 1135 | 11127 | 1362 | 13352 |
| 60 | 90 | 504 | 4932 | 755 | 7398 | 1006 | 9864 | 1415 | 13871 | 1698 | 16645 |
| 64 | 95 | 608 | 5960 | 912 | 8940 | 1216 | 11920 | 1710 | 16762 | 2052 | 20115 |
| 68 | 100 | 738 | 7230 | 1107 | 10845 | 1475 | 14460 | 2075 | 20335 | 2450 | 24401 |
| 72 | 105 | 885 | 8669 | 1327 | 13003 | 1769 | 17337 | 2488 | 24381 | 2985 | 29257 |
| 76 | 110 | 1050 | 10287 | 1574 | 15430 | 2099 | 20573 | 2952 | 28931 | | 34717 |
| 80 | 115 | 1234 | 12094 | 1851 | 18141 | 2468 | 24188 | 3471 | 34014 | | 40815 |
| 85 | 120 | 1493 | 14636 | 2240 | 21953 | 2987 | 29271 | | 41163 | | 49395 |
| 90 | 130 | 1787 | 17510 | 2680 | 26266 | 3573 | 35021 | | 49248 | | 59098 |
| 100 | 145 | 2484 | 24341 | 3726 | 36512 | | 48683 | | 68460 | | 82152 |
| 110 | 155 | 3342 | 32751 | | 49126 | | 65501 | | 92111 | | 110533 |
| 120 | 175 | 4378 | 42902 | | 64354 | | 85805 | | 120663 | | 144795 |
| 125 | 180 | | 48683 | | 73024 | | 97366 | | 136920 | | 164304 |

Note: The values in the table are measured when the bolt reaches 60% of the yield limit.

The recommended tightening torque is: the value in the table × (70-80)%

For example: M52, 8.8 grade bolt, the tightening torque is 6362 × (70-80)% = 4453-5090 N.m

The loosening torque is 1.5-2 times the tightening torque

For example: in the above example, the tightening torque is 4453 N.m, then the loosening torque is 4453 × 2 = 8906 N.m

V. Operation and Use

Connect:

The wrench and the hydraulic pump are connected by the compound oil pipe woven with steel wire with working pressure of 700bar.

The bottom end of each oil pipe has a female connector and a male connector to ensure the correct connection between the pump and the wrench.

Do not change any bolts on the rotary joint at will. This is set by the manufacturer for safety. Only those who have received professional training can adjust

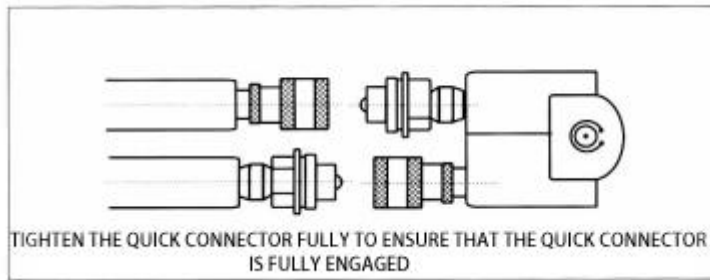

F (3)

When the quick connectors are interconnected, the distance between the gaps after engagement must be less than 1mm (Figure 4). Only in this way can the one-way valve in the connector be opened to make the oil path unblocked. Otherwise, after the connection, the steel ball in the joint does not match up, and the one-way valve in the joint cannot be opened and the oil circuit is blocked. Then the joint will be full of pressure, and the wrench will not work and the oil will be discharged from the automatic drain port on the wrench rotating body, etc.

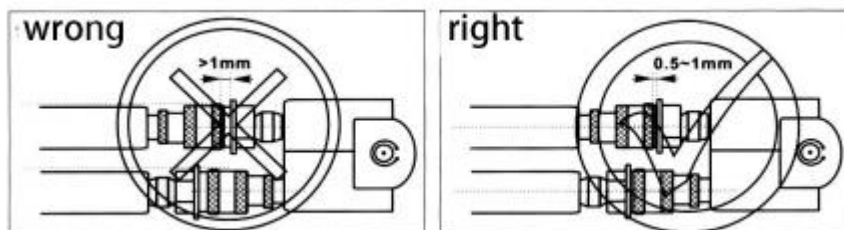

F (4)

At this time, you need to disassemble all the hose joints, check all the steel balls in the quick joints, including the wrench joints, and check whether the steel balls can be pressed with your hands and are flexible. If you can't press it, you need to find a hammer to hit the steel ball in the joint (Figure 5) to release the pressure in the joint (please note that hydraulic oil will spray out when you hit the steel ball. Although it is not dangerous, it will stain your Clothes!) until the steel ball in the joint can be pressed by hand. Then reconnect again.

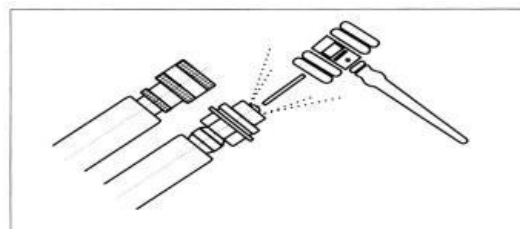

F (5)

MXTD Series

Changing over of the drive

Press the round button in the middle of the locker (Figure 6), and gently pull the drive shaft to release the engagement between the drive shaft and the locker, and then the drive shaft can be pulled out.

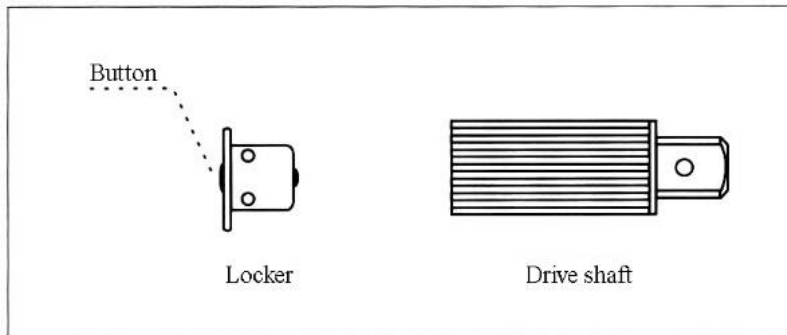
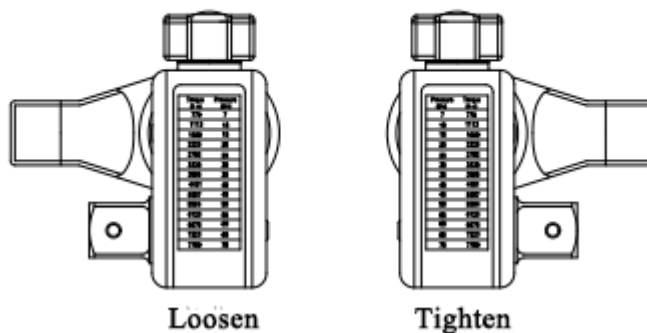

Figure (6)

Put the drive shaft into the wrench, determine the direction (Figure 7), make it fully mesh with the spline sleeve, then rotate the drive shaft to mesh with the spline sleeve and the ratchet groove, and drive the drive shaft to rotate through the ratchet.



Left-Loosen

Right-Tighten

Figure (7)

Preparation

Determine whether to loosen or tighten the nut.

Press down the drive shaft locker; take out the square drive shaft; perform left-right reversal according to the diagram, and install the drive shaft locker; connect the arm clamp on the reaction arm, and install the reaction arm according to the appropriate position. When removing the lock, the direction of the square shaft is shown in the figure (7).

Connect pump station

Connect the high-pressure outlet (H or A) of the pump with the high-pressure outlet (H or A) of the hydraulic wrench, and connect the low-pressure outlet (B or R) of the pump with the low-pressure outlet (B or R) of the hydraulic wrench with high-pressure hose respectively. When connecting, the quick connector on the oil pipe should be inserted to the end, and then tighten the fixing nut by hand.

Check carefully whether the oil pipe joints are connected reliably and whether there is oil in the pump.

Plug the power plug of the pump into the power source.

Warning Operation without oil is strictly prohibited!

Commissioning

Place the wrench on the open floor.

Turn on the power switch of the pump, start the pump, and check whether the pump is running normally.

Press any button on the wire control switch, and the square shaft starts to rotate at this time. When you hear a "click", the reset trigger jumps down, the wrench stops rotating when it is in place, and the pressure gauge rises from "0" to the set pressure. Release the button and the wrench will return automatically;

When a "click" is heard again, the wrench will automatically return to its position, and the pressure gauge will rise rapidly from "0" to 7.5Mpa. Press the button again, at this time the wrench turns, and a new cycle begins. Repeat several times, let the wrench run idly several times, and observe the direction of the wrench to determine whether to put the wrench on the socket.

Note: When the wrench is not in use, turn off the power of the oil pump immediately!

Operating

Adjust pressure

Press the line control switch button with one hand. When you hear a "click" of the wrench, the reset trigger jumps down, the wrench stops rotating when the wrench is in place, and the pressure gauge rises rapidly from "0", and adjusts the oil pump pressure regulating valve with the other hand to adjust the pressure gauge pointer to the required pressure.

Loosening

Adjust the pumping station pressure to the highest, confirm the rotating direction of the wrench. After confirming the direction is to loosen, put the wrench on the nut, find the reaction fulcrum, hold it firmly, and repeat the third action in the Commissioning until the nut is removed.

Tightening

1. Torque setting

First, the torque can be set according to the design requirements; if there is no design torque, it is recommended to set the torque according to the data in the bolt pre-tightening force recommendation table.

The specific method is: $\text{set torque} = (\text{value in the table}) \times (70\%-80\%)$

For example: 8.8 grade, M48 is a bolt, the recommended pre-tightening force in the table is 4921N.m, then the set torque is: $4921 \times 75\% = 3691\text{N.m}$.

2. Pump station pressure setting

Set the pumping station pressure according to the required torque value and the type of wrench used.

For example, the bolt setting torque of the above 8.8 level and M48 is 3691N.m, and select the 3MXTD wrench. From the table, you can check that when the 3MXTD corresponds to the 3691N.m torque, the pump station pressure is 59Mpa, so the pump station pressure should be set to 59Mpa.

3. Make sure that the direction of the wrench is in the tightening direction, and place the wrench on the nut and repeat the actions of the third item in the Commissioning until the nut does not move.

When the wrench is stuck tightly during use:

In operation, after the bolts are tightened, if the wrench cannot be removed, do not hit it with a hammer; instead, press and hold the wire control switch (button), then press and hold the quick release lever(Figure 12) and at this time release the button, the wrench will be automatically released. Remove the wrench then.

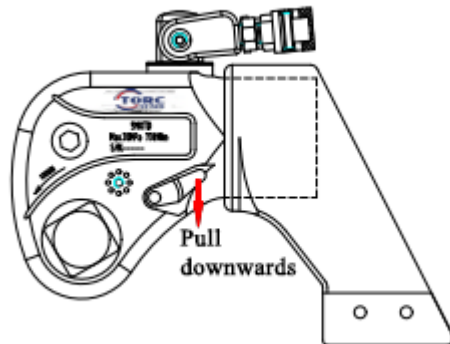
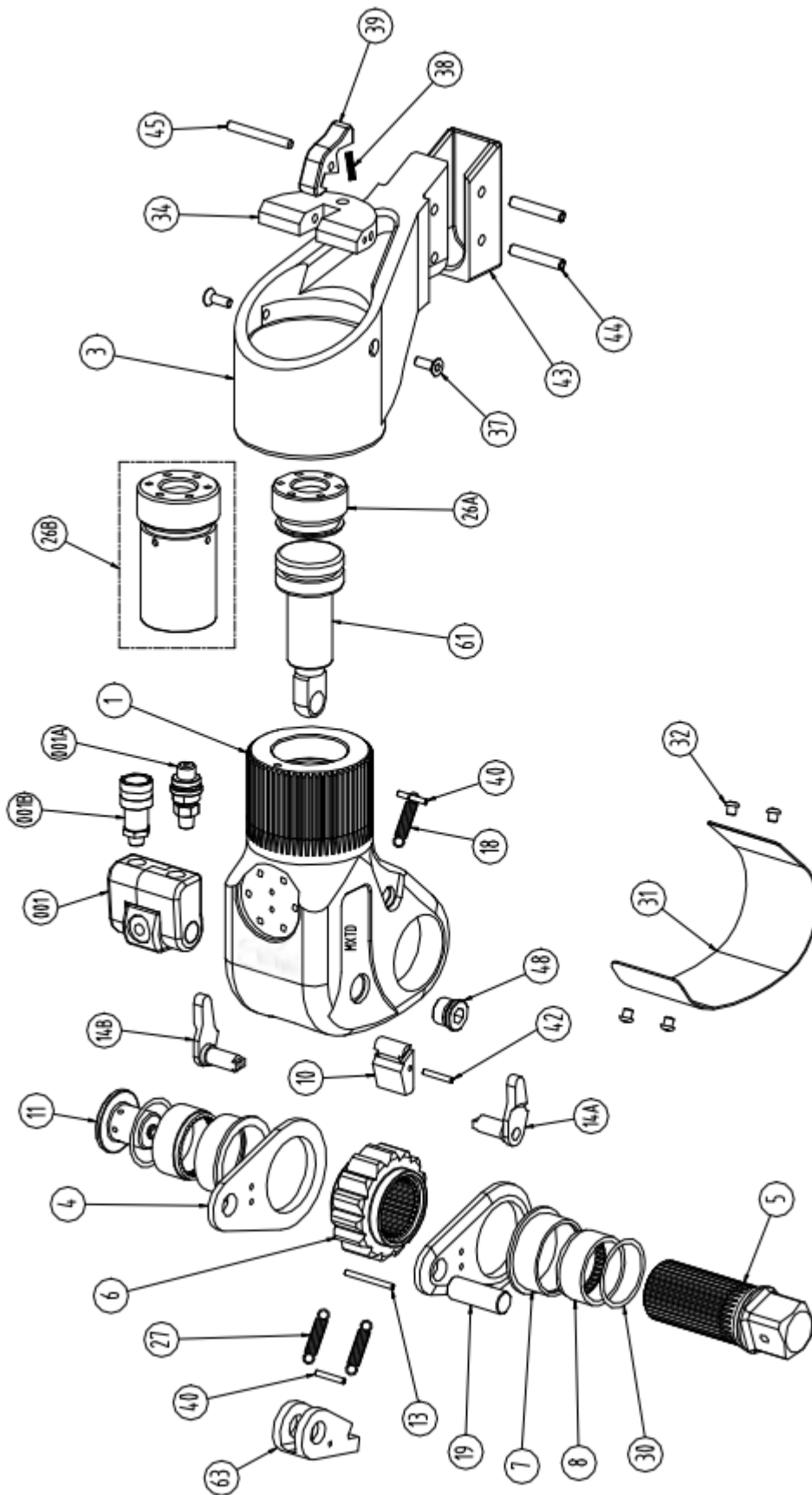

Figure (8)

VI. MXTD Hydraulic Torque Wrench Pressure-torque Comparison Table

| Model | 1MXTD | 3MXTD | 5MXTD | 8MXTD | 10MXTD | 15MXTD | 20MXTD | 25MXTD | 35MXTD | 45MXTD | 50MXTD |
|--------------|-----------|-----------|-----------|-----------|-----------|-----------|-----------|-----------|-----------|-----------|-----------|
| Pressure MPa | Torque Nm | Torque Nm | Torque Nm | Torque Nm | Torque Nm | Torque Nm | Torque Nm | Torque Nm | Torque Nm | Torque Nm | Torque Nm |
| 7 | 185 | 436 | 779 | 1072 | 1553 | 2050 | 2617 | 3493 | 4963 | 6009 | 7032 |
| 8 | 212 | 499 | 890 | 1225 | 1775 | 2343 | 2991 | 3992 | 5672 | 6867 | 8036 |
| 9 | 238 | 561 | 1001 | 1378 | 1996 | 2636 | 3365 | 4491 | 6381 | 7726 | 9041 |
| 10 | 265 | 623 | 1113 | 1531 | 2218 | 2929 | 3739 | 4990 | 7090 | 8584 | 10045 |
| 11 | 291 | 686 | 1224 | 1684 | 2440 | 3222 | 4113 | 5489 | 7798 | 9442 | 11050 |
| 12 | 318 | 748 | 1335 | 1837 | 2662 | 3514 | 4486 | 5988 | 8507 | 10301 | 12054 |
| 13 | 344 | 810 | 1447 | 1990 | 2884 | 3807 | 4860 | 6487 | 9216 | 11159 | 13059 |
| 14 | 370 | 873 | 1558 | 2143 | 3106 | 4100 | 5234 | 6986 | 9925 | 12018 | 14063 |
| 15 | 397 | 935 | 1669 | 2296 | 3327 | 4393 | 5608 | 7484 | 10634 | 12876 | 15068 |
| 16 | 423 | 998 | 1780 | 2449 | 3549 | 4686 | 5982 | 7983 | 11343 | 13734 | 16072 |
| 17 | 450 | 1060 | 1892 | 2602 | 3771 | 4979 | 6356 | 8482 | 12052 | 14593 | 17077 |
| 18 | 476 | 1122 | 2003 | 2755 | 3993 | 5272 | 6730 | 8981 | 12761 | 15451 | 18081 |
| 19 | 503 | 1185 | 2114 | 2908 | 4215 | 5565 | 7104 | 9480 | 13470 | 16310 | 19086 |
| 20 | 529 | 1247 | 2225 | 3062 | 4436 | 5857 | 7477 | 9979 | 14179 | 17168 | 20090 |
| 21 | 556 | 1309 | 2337 | 3215 | 4658 | 6150 | 7851 | 10478 | 14888 | 18026 | 21095 |
| 22 | 582 | 1372 | 2448 | 3368 | 4880 | 6443 | 8225 | 10977 | 15597 | 18885 | 22099 |
| 23 | 609 | 1434 | 2559 | 3521 | 5102 | 6736 | 8599 | 11476 | 16306 | 19743 | 23104 |
| 24 | 635 | 1496 | 2671 | 3674 | 5324 | 7029 | 8973 | 11975 | 17015 | 20602 | 24108 |
| 25 | 662 | 1559 | 2782 | 3827 | 5546 | 7322 | 9347 | 12474 | 17724 | 21460 | 25113 |
| 26 | 688 | 1621 | 2893 | 3980 | 5767 | 7615 | 9721 | 12973 | 18433 | 22318 | 26117 |
| 27 | 715 | 1683 | 3004 | 4133 | 5989 | 7908 | 10095 | 13472 | 19142 | 23177 | 27122 |
| 28 | 741 | 1746 | 3116 | 4286 | 6211 | 8200 | 10468 | 13971 | 19851 | 24035 | 28126 |
| 29 | 767 | 1808 | 3227 | 4439 | 6433 | 8493 | 10842 | 14470 | 20560 | 24894 | 29131 |
| 30 | 794 | 1870 | 3338 | 4592 | 6655 | 8786 | 11216 | 14969 | 21269 | 25752 | 30135 |
| 31 | 820 | 1933 | 3449 | 4745 | 6876 | 9079 | 11590 | 15468 | 21978 | 26610 | 31140 |
| 32 | 847 | 1995 | 3561 | 4898 | 7098 | 9372 | 11964 | 15967 | 22687 | 27469 | 32144 |
| 33 | 873 | 2057 | 3672 | 5051 | 7320 | 9665 | 12338 | 16466 | 23395 | 28327 | 33149 |
| 34 | 900 | 2120 | 3783 | 5205 | 7542 | 9958 | 12712 | 16965 | 24104 | 29186 | 34153 |
| 35 | 926 | 2182 | 3895 | 5358 | 7764 | 10251 | 13086 | 17464 | 24813 | 30044 | 35158 |
| 36 | 953 | 2244 | 4006 | 5511 | 7986 | 10543 | 13459 | 17963 | 25522 | 30902 | 36162 |
| 37 | 979 | 2307 | 4117 | 5664 | 8207 | 10836 | 13833 | 18462 | 26231 | 31761 | 37167 |
| 38 | 1006 | 2369 | 4228 | 5817 | 8429 | 11129 | 14207 | 18961 | 26940 | 32619 | 38171 |
| 39 | 1032 | 2431 | 4340 | 5970 | 8651 | 11422 | 14581 | 19460 | 27649 | 33478 | 39176 |
| 40 | 1059 | 2494 | 4451 | 6123 | 8873 | 11715 | 14955 | 19959 | 28358 | 34336 | 40180 |
| 41 | 1085 | 2556 | 4562 | 6276 | 9095 | 12008 | 15329 | 20458 | 29067 | 35194 | 41185 |
| 42 | 1111 | 2618 | 4673 | 6429 | 9317 | 12301 | 15703 | 20957 | 29776 | 36053 | 42189 |
| 43 | 1138 | 2681 | 4785 | 6582 | 9538 | 12594 | 16077 | 21456 | 30485 | 36911 | 43194 |
| 44 | 1164 | 2743 | 4896 | 6735 | 9760 | 12886 | 16450 | 21954 | 31194 | 37769 | 44198 |
| 45 | 1191 | 2806 | 5007 | 6888 | 9982 | 13179 | 16824 | 22453 | 31903 | 38628 | 45203 |
| 46 | 1217 | 2868 | 5119 | 7041 | 10204 | 13472 | 17198 | 22952 | 32612 | 39486 | 46207 |
| 47 | 1244 | 2930 | 5230 | 7195 | 10426 | 13765 | 17572 | 23451 | 33321 | 40345 | 47212 |
| 48 | 1270 | 2993 | 5341 | 7348 | 10647 | 14058 | 17946 | 23950 | 34030 | 41203 | 48216 |
| 49 | 1297 | 3055 | 5452 | 7501 | 10869 | 14351 | 18320 | 24449 | 34739 | 42061 | 49221 |
| 50 | 1323 | 3117 | 5564 | 7654 | 11091 | 14644 | 18694 | 24948 | 35448 | 42920 | 50225 |
| 51 | 1350 | 3180 | 5675 | 7807 | 11313 | 14936 | 19068 | 25447 | 36157 | 43778 | 51230 |
| 52 | 1376 | 3242 | 5786 | 7960 | 11535 | 15229 | 19441 | 25946 | 36866 | 44637 | 52234 |
| 53 | 1403 | 3304 | 5898 | 8113 | 11757 | 15522 | 19815 | 26445 | 37575 | 45495 | 53239 |
| 54 | 1429 | 3367 | 6009 | 8266 | 11978 | 15815 | 20189 | 26944 | 38283 | 46353 | 54243 |
| 55 | 1456 | 3429 | 6120 | 8419 | 12200 | 16108 | 20563 | 27443 | 38992 | 47212 | 55248 |
| 56 | 1482 | 3491 | 6231 | 8572 | 12422 | 16401 | 20937 | 27942 | 39701 | 48070 | 56252 |
| 57 | 1508 | 3554 | 6343 | 8725 | 12644 | 16694 | 21311 | 28441 | 40410 | 48929 | 57257 |
| 58 | 1535 | 3616 | 6454 | 8878 | 12866 | 16987 | 21685 | 28940 | 41119 | 49787 | 58261 |
| 59 | 1561 | 3678 | 6565 | 9031 | 13088 | 17279 | 22059 | 29439 | 41828 | 50645 | 59266 |
| 60 | 1588 | 3741 | 6676 | 9185 | 13309 | 17572 | 22432 | 29938 | 42537 | 51504 | 60270 |
| 61 | 1614 | 3803 | 6788 | 9338 | 13531 | 17865 | 22806 | 30437 | 43246 | 52362 | 61275 |
| 62 | 1641 | 3865 | 6899 | 9491 | 13753 | 18158 | 23180 | 30936 | 43955 | 53221 | 62279 |
| 63 | 1667 | 3928 | 7010 | 9644 | 13975 | 18451 | 23554 | 31435 | 44664 | 54079 | 63284 |
| 64 | 1694 | 3990 | 7122 | 9797 | 14197 | 18744 | 23928 | 31934 | 45373 | 54937 | 64288 |
| 65 | 1720 | 4052 | 7233 | 9950 | 14418 | 19037 | 24302 | 32433 | 46082 | 55796 | 65293 |
| 66 | 1747 | 4115 | 7344 | 10103 | 14640 | 19330 | 24676 | 32932 | 46791 | 56654 | 66297 |
| 67 | 1773 | 4177 | 7455 | 10256 | 14862 | 19622 | 25050 | 33431 | 47500 | 57513 | 67302 |
| 68 | 1800 | 4239 | 7567 | 10409 | 15084 | 19915 | 25423 | 33930 | 48209 | 58371 | 68306 |
| 69 | 1826 | 4302 | 7678 | 10562 | 15306 | 20208 | 25797 | 34429 | 48918 | 59229 | 69311 |
| 70 | 1852 | 4364 | 7789 | 10715 | 15528 | 20501 | 26171 | 34928 | 49627 | 60088 | 70315 |

VII. MXTD exploded diagram and details



MXTD - Details

| No. | Item | Qt Y. | Wrench Model | | | | | | | | | |
|------|----------------------|-------|--------------|---------|---------|---------|----------|----------|----------|----------|----------|----------|
| | | | 1MXTD | 3MXTD | 5MXTD | 8MXTD | 10MXTD | 15MXTD | 20MXTD | 25MXTD | 35MXTD | 50MXTD |
| 1 | Case | 1 | 1M-1 | 3M-1 | 5M-1 | 8M-1 | 10M-1 | 15M-1 | 20M-1 | 25M-1 | 35M-1 | 50M-1 |
| 3 | Reaction Arm | 1 | 1M-3 | 3M-3 | 5M-3 | 8M-3 | 10M-3 | 15M-3 | 20M-3 | 25M-3 | 35M-3 | 50M-3 |
| 4 | Baffle | 2 | 1M-4 | 3M-4 | 5M-4 | 8M-4 | 10M-4 | 15M-4 | 20M-4 | 25M-4 | 35M-4 | 50M-4 |
| 5 | Drive shaft | 1 | 1M-5 | 3M-5 | 5M-5 | 8M-5 | 10M-5 | 15M-5 | 20M-5 | 25M-5 | 35M-5 | 50M-5 |
| 6 | Ratchet | 1 | 1M-6 | 3M-6 | 5M-6 | 8M-6 | 10M-6 | 15M-6 | 20M-6 | 25M-6 | 35M-6 | 50M-6 |
| 7 | Bushing | 2 | 1M-7 | 3M-7 | 5M-7 | 8M-7 | 10M-7 | 15M-7 | 20M-7 | 25M-7 | 35M-7 | 50M-7 |
| 8 | Copper sleeve | 2 | 1M-8 | 3M-8 | 5M-8 | 8M-8 | 10M-8 | 15M-8 | 20M-8 | 25M-8 | 35M-8 | 50M-8 |
| 10 | Non-return claw | 1 | 1M-10 | 3M-10 | 5M-10 | 8M-10 | 10M-10 | 15M-10 | 20M-10 | 25M-10 | 35M-10 | 50M-10 |
| 11 | Magnesium fixing cap | 1 | 1M-11 | 3M-11 | 5M-11 | 8M-11 | 10M-11 | 15M-11 | 20M-11 | 25M-11 | 35M-11 | 50M-11 |
| 13 | Elastic pin | 1 | 1M-13 | 3M-13 | 5M-13 | 8M-13 | 10M-13 | 15M-13 | 20M-13 | 25M-13 | 35M-13 | 50M-13 |
| 14A | Trigger-right | 1 | 1M-14A | 3M-14A | 5M-14A | 8M-14A | 10M-14A | 15M-14A | 20M-14A | 25M-14A | 35M-14A | 50M-14A |
| 14B | Trigger-left | 1 | 1M-14B | 3M-14B | 5M-14B | 8M-14B | 10M-14B | 15M-14B | 20M-14B | 25M-14B | 35M-14B | 50M-14B |
| 18 | Check spring | 1 | 1M-18 | 3M-18 | 5M-18 | 8M-18 | 10M-18 | 15M-18 | 20M-18 | 25M-18 | 35M-18 | 50M-18 |
| 19 | Pin shaft | 1 | 1M-19 | 3M-19 | 5M-19 | 8M-19 | 10M-19 | 15M-19 | 20M-19 | 25M-19 | 35M-19 | 50M-19 |
| 26A | Bottom cover | 1 | 1M-26A | 3M-26A | 5M-26A | 8M-26A | 10M-26A | 15M-26A | 20M-26A | 25M-26A | 35M-26A | 50M-26A |
| 26B | Steel sleeve | 1 | 1M-26B | 3M-26B | 5M-26B | 8M-26B | 10M-26B | 15M-26B | 20M-26B | 25M-26B | 35M-26B | 50M-26B |
| 27 | Pawl spring | 2 | 1M-27 | 3M-27 | 5M-27 | 8M-27 | 10M-27 | 15M-27 | 20M-27 | 25M-27 | 35M-27 | 50M-27 |
| 30 | Snap ring | 2 | 1M-30 | 3M-30 | 5M-30 | 8M-30 | 10M-30 | 15M-30 | 20M-30 | 25M-30 | 35M-30 | 50M-30 |
| 31 | Dustproof board | 1 | 1M-31 | 3M-31 | 5M-31 | 8M-31 | 10M-31 | 15M-31 | 20M-31 | 25M-31 | 35M-31 | 50M-31 |
| 32 | Flat head screws | 4 | 1M-32 | 3M-32 | 5M-32 | 8M-32 | 10M-32 | 15M-32 | 20M-32 | 25M-32 | 35M-32 | 50M-32 |
| 34 | Claw fixing plate | 1 | 1M-34 | 3M-34 | 5M-34 | 8M-34 | 10M-34 | 15M-34 | 20M-34 | 25M-34 | 35M-34 | 50M-34 |
| 37 | Countersunk screw | 2 | 1M-37 | 3M-37 | 5M-37 | 8M-37 | 10M-37 | 15M-37 | 20M-37 | 25M-37 | 35M-37 | 50M-37 |
| 38 | Claw spring | 1 | 1M-38 | 3M-38 | 5M-38 | 8M-38 | 10M-38 | 15M-38 | 20M-38 | 25M-38 | 35M-38 | 50M-38 |
| 39 | Claw | 1 | 1M-39 | 3M-39 | 5M-39 | 8M-39 | 10M-39 | 15M-39 | 20M-39 | 25M-39 | 35M-39 | 50M-39 |
| 40 | Elastic pin | 2 | 1M-40 | 3M-40 | 5M-40 | 8M-40 | 10M-40 | 15M-40 | 20M-40 | 25M-40 | 35M-40 | 50M-40 |
| 42 | Elastic pin | 1 | 1M-42 | 3M-42 | 5M-42 | 8M-42 | 10M-42 | 15M-42 | 20M-42 | 25M-42 | 35M-42 | 50M-42 |
| 43 | Protective pad | 1 | 1M-43 | 3M-43 | 5M-43 | 8M-43 | 10M-43 | 15M-43 | 20M-43 | 25M-43 | 35M-43 | 50M-43 |
| 44 | Elastic pin | 2 | 1M-44 | 3M-44 | 5M-44 | 8M-44 | 10M-44 | 15M-44 | 20M-44 | 25M-44 | 35M-44 | 50M-44 |
| 45 | Claw pin | 1 | 1M-45 | 3M-45 | 5M-45 | 8M-45 | 10M-45 | 15M-45 | 20M-45 | 25M-45 | 35M-45 | 50M-45 |
| 48 | Pin hole cap | 2 | 1M-48 | 3M-48 | 5M-48 | 8M-48 | 10M-48 | 15M-48 | 20M-48 | 25M-48 | 35M-48 | 50M-48 |
| 61 | Piston group | 1 | 1M-61 | 3M-61 | 5M-61 | 8M-61 | 10M-61 | 15M-61 | 20M-61 | 25M-61 | 35M-61 | 50M-61 |
| 63 | Pawl | 1 | 1M-63 | 3M-63 | 5M-63 | 8M-63 | 10M-63 | 15M-63 | 20M-63 | 25M-63 | 35M-63 | 50M-63 |
| 001 | Connector group | 1 | 1M-001 | 3M-001 | 5M-001 | 8M-001 | 10M-001 | 15M-001 | 20M-001 | 25M-001 | 35M-001 | 50M-001 |
| 001A | Push-in connector | 1 | 1M-001A | 3M-001A | 5M-001A | 8M-001A | 10M-001A | 15M-001A | 20M-001A | 25M-001A | 35M-001A | 50M-001A |
| 001B | push-in connector | 1 | 1M-001B | 3M-001B | 5M-001B | 8M-001B | 10M-001B | 15M-001B | 20M-001B | 25M-001B | 35M-001B | 50M-001B |

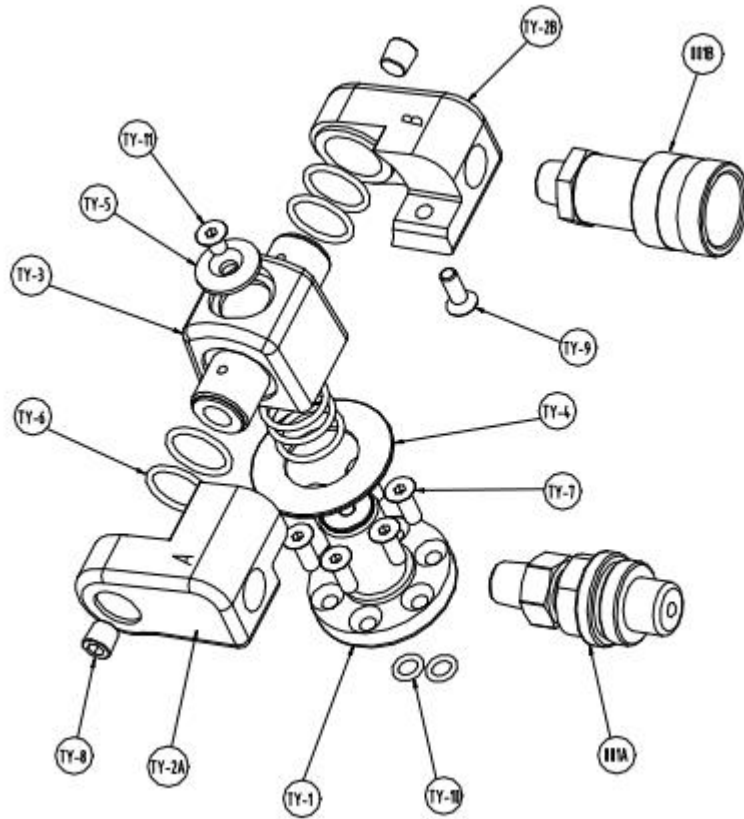

| No. | Item | Qty. | Model |
|-------|----------------------------------|------|-----------|
| TY-1 | Connector base | 1 | - |
| TY-2A | Connector-A | 1 | - |
| TY-2B | Connector-B | 1 | - |
| TY-3 | Connector body | 1 | - |
| TY-4 | Cover plate | 1 | - |
| TY-5 | Cap | 1 | - |
| TY-6 | O-ring | 7 | d18*2 |
| TY-7 | Screw | 6 | M5*14 |
| TY-8 | Plugging | 2 | NPT1/8 |
| TY-9 | Screw | 1 | M5*16 |
| TY-10 | O-ring | 2 | d4.15*1.9 |
| TY-11 | Screw | 1 | M5*8 |
| 00 1A | Quick push-in connector (male) | 1 | C701E-M |
| 00 1B | Quick push-in connector (female) | 1 | C701E-F |

VIII. After-sales service

Please read this manual carefully before requesting Jingke after-sales service department to repair the wrench. Please do not repair the wrench by yourself without the approval of the authoritative department of our company.

Pingyuan Jingke Hydraulic Co., Ltd

Address: Juncang Industrial Park, Dezhou City, Shandong, China

Tel: 0531 - 82899663